

## EG-491

Certificada ISO 9001/2008

**EGEMAF**  
COMPONENTES ELETROMECÂNICOS LTDA.

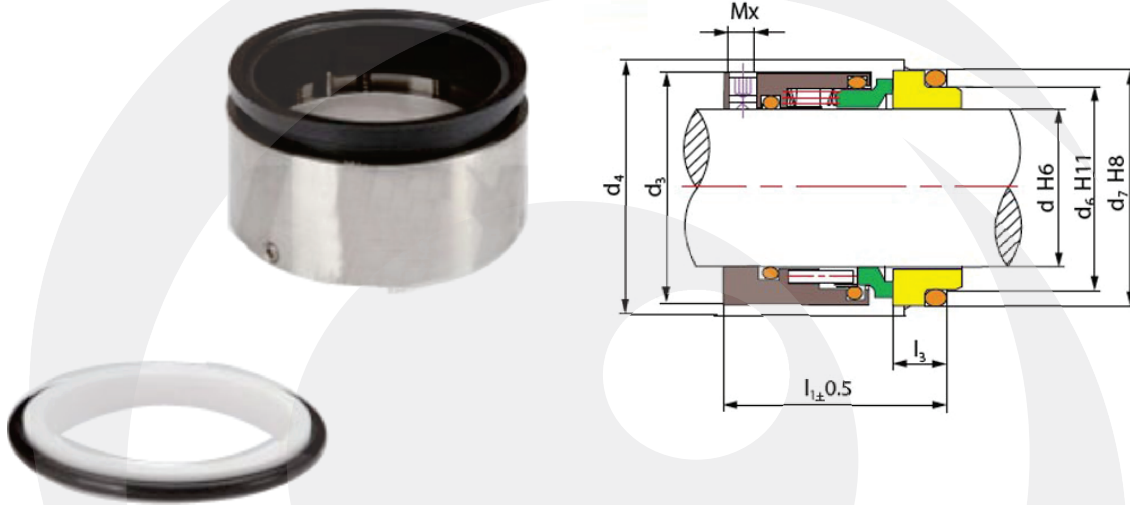

## Limites operacionais:

Pressão < 1MPa  
Velocidade < 10m/s  
Temperatura: -30°C~+ 180°C

## Operating limits:

Pressure < 1MPa  
Speed < 10m/s  
Temperature: -30°C~+ 180°C

- Anel Giratório (Carvão/SiC/TC)
  - Anel Estacionário (99% Cerâmica/SiC/TC)
  - Selo Secundário (NBR/VITON/EPDM)
  - Mola (SUS316/Hastalloy-c)
  - Outras Peças (SUS304/SUS316)
- 
- Rotary Ring (Carbon/SiC/TC)
  - Stationary Ring (99% Ceramic/SiC/TC)
  - Secondary Seal (NBR/VITON/EPDM)
  - Spring (SUS316/Hastalloy-c)
  - Other Parts (SUS304/SUS316)

seal size d(mm)	d <sub>3</sub>	d <sub>4</sub>	d <sub>6</sub>	d <sub>7</sub>	l <sub>1</sub>	l <sub>3</sub>	MX
16	29	31	23	27	35.0	5.0	4
18	32	34	27	33	37.5	7.5	4
20	34	36	29	35	37.5	7.5	4
22	36	38	31	37	37.5	7.5	4
24	38	40	33	39	37.5	7.5	4
25	39	41	34	40	37.5	7.5	4
28	42	44	37	43	42.5	7.5	5
30	44	46	39	45	42.5	7.5	5
32	46	48	42	48	42.5	7.5	5
33	47	49	42	48	42.5	7.5	5
35	49	51	44	50	42.5	7.5	5
38	54	58	49	56	44.0	9.0	5
40	56	60	51	58	44.0	9.0	5
43	59	63	54	61	44.0	9.0	5
45	61	65	56	63	44.0	9.0	5
48	64	68	59	66	44.0	9.0	5
50	66	70	62	70	44.5	9.5	5
53	69	73	65	73	46.0	11.0	5
55	71	75	67	75	46.0	11.0	5
60	80	85	72	80	46.0	11.0	5
65	85	90	77	85	46.0	11.0	5
68	88	93	81	90	46.3	11.3	5
70	90	95	83	92	46.3	11.3	5
75	99	104	88	97	59.3	11.3	6
80	104	109	95	105	60.0	12.0	6
85	109	114	100	110	60.0	12.0	6
90	114	119	105	115	62.0	14.0	6
100	124	129	115	125	62.0	14.0	6
110	134	139	125	135	62.0	14.0	6